

Stayflex™ Anterior Trunk Support

INSTALLATION AND USER'S INSTRUCTIONS

SH350, SH351, SH360, SH361

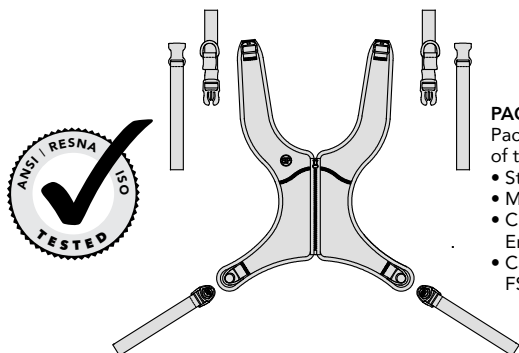

PACKAGE CONTENTS

Package may contain one or more of the following:

- Stayflex Shoulder Harness
- Multi-directional Top Straps
- Cinch-Mount or Flat-Mount End-Fittings
- Cam Buckles (Optional – Art No. FS032-2)

These instructions provide important information for the safe use and maintenance of all Bodypoint Stayflex™ Anterior Trunk Supports. Give these instructions to the user or their caregiver and review them to ensure that they are understood.

⚠ WARNING! Product should be installed and fitted by a qualified rehab technician.

For installation, this product should be mounted with:

- Flat-Mount end-fittings
- Cinch-Mount end-fittings
- Cam buckle (suitable for users up to 75kg)

Optional Bodypoint belt mounting hardware may be used for mounting to wheelchairs and seating systems.

⚠ WARNING! Because of the risk of choking, it is dangerous to use this product without stabilizing the pelvis – always use with a properly fitted pelvic support belt.

USE:

⚠ WARNING! This product should only be used for positioning a person in a wheelchair or work chair. It is NOT intended for use as a transportation safety device, as a personal restraint device, or in any other application where its failure could result in injury. Misuse of this product is unauthorized and unsafe.

⚠ WARNING! Accidental release of this Stayflex Anterior Trunk Support can allow the user to fall forward. If the user's movements or cognitive abilities could lead to accidental release, a caregiver must be present at all times during its use. Ensure that all caregivers know how to unfasten the product. Failure to do so may delay release in an emergency.

⚠ WARNING! As with any new seating support, this product may change the way a person sits. Users must continue to practice regular pressure relief activities and skin integrity checks, not only where this product contacts the user, but also in primary pressure-bearing areas such as the sacrum, legs, and buttocks. If increased skin redness or irritation occurs, discontinue use and consult your physician or seating specialist. Failure to do so may result in serious injury, such as pressure ulcers.

MAINTENANCE: Check periodically for signs of wear in the stitching, webbing, and pads. If significant wear is found, contact your supplier for qualified repair or replacement by Bodypoint. Under no circumstance should this product be altered or repaired by unqualified persons—health and safety depend on it!

🧼 CLEANING: Machine wash, hot, 60°C (140°F). Do not bleach. Tumble dry, low temperature, or drip dry. Do not iron. (Placing the product inside a cloth bag during washing helps prevent scratches to the product and the machine.)

WARRANTY: This product carries a limited lifetime warranty against defects in workmanship and materials arising under normal use by the original consumer. Contact your supplier or Bodypoint for warranty claims.

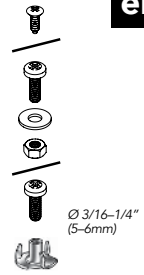
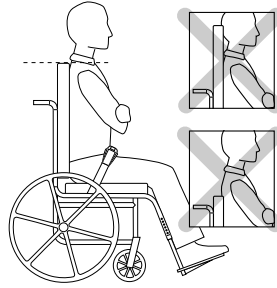
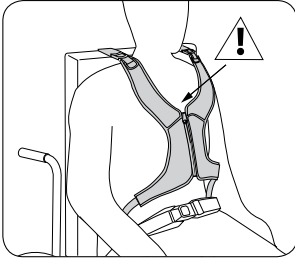

INSTALLATION

Seat user in wheelchair and establish correct posture with Pelvic Support Belt. Place Stayflex pad on chest and drape upper straps over backrest.

⚠ Top of zipper should never rise above user's sternum.

INSTALLATION REQUIREMENTS

1. Wheelchair with a solid backrest or strap guides set approximately at shoulder height (adjust up/down for pressure distribution).
2. Mounting screws with a minimum pullout strength of 90kg (200lbs) (Not included in package).

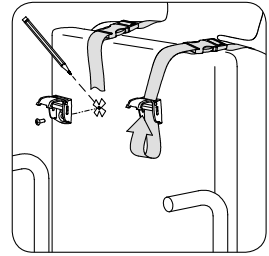
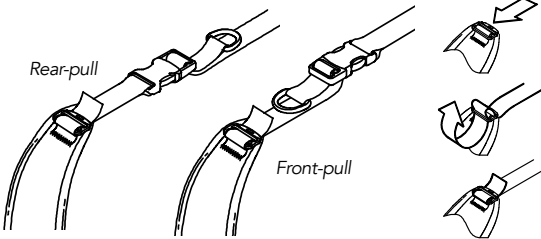

TOP STRAPS

1. Determine desired adjustment pull direction and attach top strap to harness.
2. Adjust each shoulder strap for a comfortable fit, according to the user's shoulder width and sitting position. Mark backrest for mounting screws.
3. Attach to backrest using Bodypoint end-fittings and suitable fasteners.

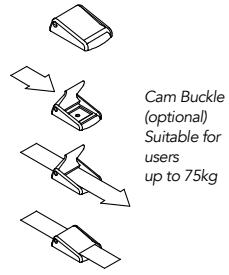
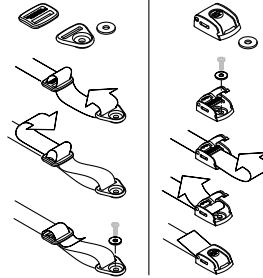
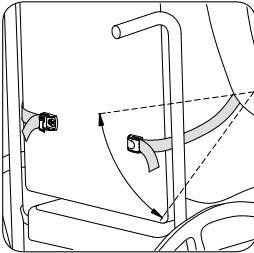

LOWER STRAPS

Wrap lower straps around backrest without obstructing other devices on wheelchair. Mount end-fittings between the lowest rib and the seat. Attach using suitable fasteners.

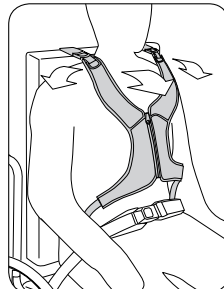
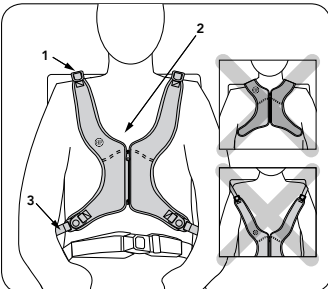

SAFETY CHECK

Have user lean forward and from side to side to check fit. Check for:

1. **Comfort** If rubbing neck, relocate upper straps.
2. **Position** If too high or too low, adjust lower straps.
3. **Interference with other devices** Relocate straps as necessary to clear seat tilting mechanism, armrests, accessory pads, or feeding tubes.